

bosal

**Инструкция
по монтажу тягово-сцепного
устройства шарового типа 1909 А
для автомобилей
Skoda Octavia
(Lim. And Combi)**

	96/12 –22004/5...
	1750
	1200
	75
D, .	7,0
	14,9



462800,

« - »
18
: (35363) 7-05-06

/ : (35363) 7-13-20

(495) 785-66-07

www.bosal-autoflex.ru

« - »:	(8182) 22-48-15
"	" 8(8442) 98-74-98
"	" 8(343) 379-39-89, 373-42-73
"	" 8(343) 26-88-308
"	" 8(3952) 710-194
"	" 8(495) 777-54-59
"	" 8(495) 745-79-11
"	" 8(495) 788-95-97
"	" 8(495) 720-51-03
"	" 8(3532) 57-99-85
"	" 8-905-899-5012
"	" 8(383) 291-59-60
"	" 8(831) 279-53-24
"	" 8(3422) 98-27-20
"	" 8(342) 220-87-87
"	" 8-927-002-90-06
"	" 8(3462) 24-00-44
"	" 8(3842) 21-14-76
"	" 8-902-940-4151
"	" 8(3452) 32-22-12, 41-52-62
"	" 8-961-213-0278
"	" 8-917-347-1700
"	" 8(351) 269-44-75, 900-72-73
"	" 8(3512) 773-76-91

41.55-2005.

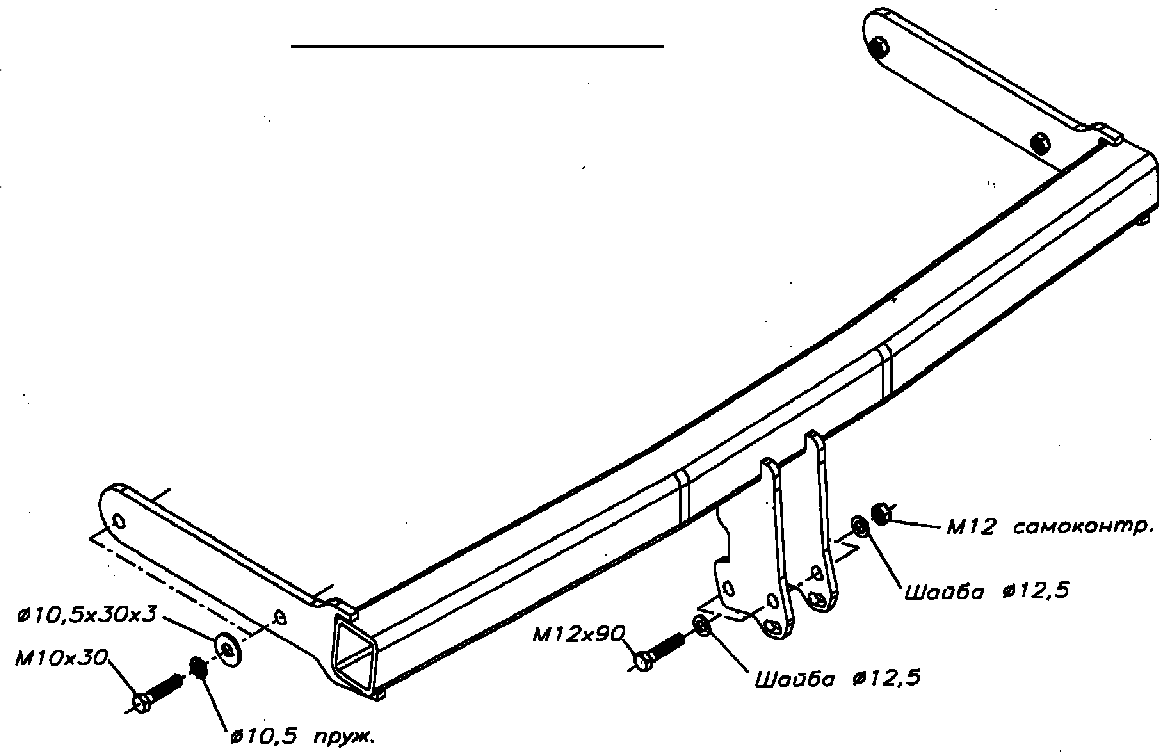

	1	.
	1	.
	1	.

		3	.
12x1.25 /		2	.
12 1.25x90		2	.
10 30		4	.
12		4	.
10		4	.
. 10		4	.
VH 0164		1	.
		2	.
		1	.
		1	.
		1	.
	190	1	.
		1	.
		1	.

1			
2			
3			
4			
5			
6			
7			

